

# SharkBite®

## Brass PEX Press Ball Valves

SharkBite® PEX Press Ball Valves are designed for use with PEX-a and PEX-b tubing and must be installed using approved press tools for fittings designed to ASTM F3347/F3348. SharkBite PEX Press fittings are backed by a 25-year system warranty when installed as part of a SharkBite system.

### Applications

Residential and commercial potable water, recirculation, reclaimed water systems, hydronic heating/cooling (up to 50% glycol concentration) and direct burial with proper wrapping.

### Specifications Data

Materials	
Body	Lead Free Silicon Brass
Sleeve	304 Stainless Steel
Performance	
Max Working Pressure	
Max Pressure	160 psi
Max Temperature	200°F (93°C)
Compatibility	
Pipe	PEX pipe
Tool	Fittings made to F3347/F3348

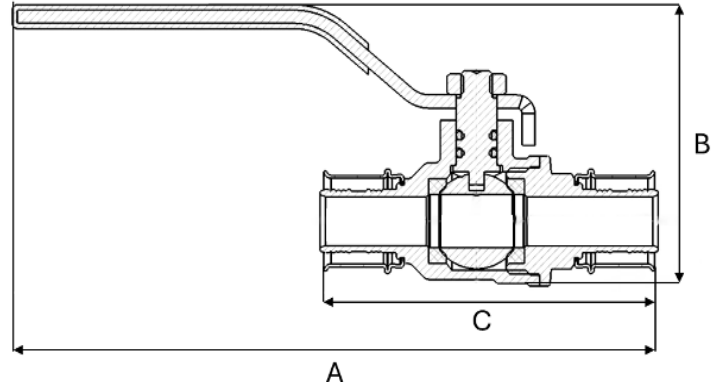

Dimensions (inches)				
Part #	Size	A	B	C
UCP22461	1/2 in.	4.83	1.99	2.58
UCP22462	3/4 in.	4.91	2.24	2.58
UCP22463	1 in.	5.62	2.70	3.37
UCPBV35	1-1/4 in.	7.39	3.41	4.47
UCPBV41	1-1/2 in.	7.59	3.65	4.86
UCPBV54	2 in.	9.33	4.45	5.59

### Certifications & Listings

ASME A112.4.14/CSA B125.14, NSF/ANSI 14, NSF/ANSI/CAN 61, NSF/ANSI/CAN 372

For listing information, please contact Customer Service

Product Submittal	
Name	
Date	
Architect/Owner	
Contractor	
Tag	
Notes	