



# SharkBite™

## Brass Angle Stop Valve

SharkBite™ expansion fittings are designed for use with PEX-a tubing and must be used in conjunction with SharkBite expansion rings. SharkBite expansion fittings have a 25-year system warranty when used with SharkBite PEX-a tubing.

### Approved Applications

Residential and commercial potable water, recirculation, reclaimed water systems, hydronic heating/cooling (up to 50% glycol concentration) and direct burial.

### Specification Data

#### Materials

Valve Bonnet	Lead-Free DZR Brass
Seal Ring	PTFE
Valve Body	Lead-Free DZR Brass
Plastic Jacket	PE
Seal Ring	PTFE
Ball	Lead-Free DZR Brass
O-ring	NBR
Valve Stem	Lead-Free DZR Brass
Handle	Steel
Screw	SST 302
Sleeve	Copper
Nut	Lead-Free DZR Brass

#### Performance

##### Max Working Pressure

80 psi	at	200°F
100 psi	at	180°F
160 psi	at	73.4°F

#### Minimum Length of Pipe Connecting Two Fittings

Fittings/Pipe Size	Min. Length	Insertion Depth
1/2 in.	2 in.	0.72 in.
3/4 in.	2-1/2 in.	0.97 in.
1 in.	3 in.	1.19 in.
1-1/4 in.	4-1/2 in.	1.46 in.
1-1/2 in.	4-1/2 in.	1.72 in.
2 in.	6 in.	2.17 in.

### Certifications & Listings

ASME A112.18.1/CSA B125.1, NSF/ANSI 14, NSF/ANSI/CAN 61, NSF/ANSI/CAN 372

For listing information, please contact Customer Service.

US 1 877 700 4242 | [sales@sharkbite.com](mailto:sales@sharkbite.com) | [sharkbite.com](http://sharkbite.com)  
 Canada 1 888 820 0120 | [canadasales@rwc.com](mailto:canadasales@rwc.com)

This information is proprietary to RWC and is subject to change without notice. It may not be reproduced in part or whole without written authorization.

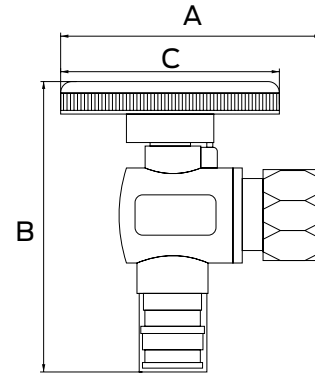

#### Dimensions (inches)

Part #	Size	A	B	C
UAB23058	1/2" x 3/8" Compression	2.10	2.40	1.71

#### Product Submittal

Name	
Date	
Architect/Owner	
Contractor	
Tag	
Notes	

Rev 2.0 / 07/17/23  
 Page 1 of 1 EN-US