



Product Submittal	
Name	
Date	
Architect/Owner	
Contractor	
Tag	
Notes	

# Cash Acme® Tankless Water Heater Installation Kit Specification Sheet

## Description

The SharkBite Tankless Water Heater Kit makes connecting to the tankless water heater easy and convenient. The valves connect directly to the cold water inlet and the hot water outlet of the tankless water heater.

## Features And Benefits

Quick and easy installation:

- Compact design works in a variety of situations, including tight spaces.

Pressure relief valve included with every kit:

- Rated to 150 psi/ 200,000 BTU.

Pressure relief valve fitting for use with pipe covers and recessed boxes:

- Greater end user safety.

Relocation adapter available:

- Allows the pressure relief valve to be rotated 360° for installation in recessed boxes or other tight spaces.

Color code steel plated handles:

- Easy identification of hot and cold valves.

Large drain port outlets available:

- Easy system cleaning & flushing.



## Specification

A Tankless Water Heater Kit shall be installed to the hot and cold water ports of the tankless water heater. The valves shall be certified to NSF/ANSI 61 and NSF/ANSI 372 standards. The SharkBite connections shall be certified to ASSE 1061 and shall be listed by a third party.

## Typical Installation

The Tankless Water Heater Kits are intended for installation directly at the tankless water heater. The cold water service valve threads directly to the cold water inlet and the hot water service valve threads directly on the hot water outlet. The pressure relief valve threads directly onto the 3/4" port on the side of the hot water service valve.

## Specification Data

### Performance:

Maximum inlet pressure	200 psi
Maximum temperature	200°F (93°C)
Service	Potable Water
Relief pressure	150 psi
Ball valve connections	3/4"

### Valve Materials:

Body	Lead Free* Brass – CW510L
Ball	T.E.A Coated Brass – CW510L
Seat	PTFE
Stem O-ring	Lead Free* Brass – CW510L
Packing	PTFE
Stem O-ring	Viton®
Packing Gland	Brass – CW614N
Handle	Steel – Geomet® Plated
Handle nut	Steel – Geomet® Plated
Handle nut	Steel – Geomet® Plated
Union washer	EPDM
Tail Piece	Lead Free* Brass – CW510L
Union Nut	Brass – CW617N
Tether	PVC
Cap	Lead Free* Brass – CW510L
Flat Washer	Buna-N

### SharkBite® Materials:

O-ring	EPDM
Grab ring	Stainless steel
Tube support liner	Polysulfone

## Codes & Standards

The valves (T104ASG) are certified to NSF/ANSI 372, NSF/ANSI/CAN 61, ANSI B1.20.1, ANSI B1.20.7. The relief valve (FWL-2) is certified to ANSI Z21.22/CSA 4.4 and are capacity certified to ASME Boiler Code Section IV. The SharkBite fittings are certified to ASSE 1061, NSF/ANSI/CAN 61, NSF/ANSI 372.



\* For all models, surfaces that are in contact with consumable water contain less than 0.25% lead by weight.

## Dimensions

### Cold Valve

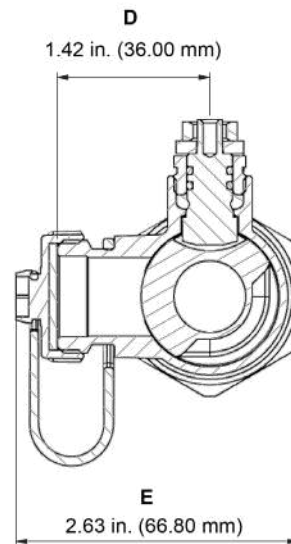
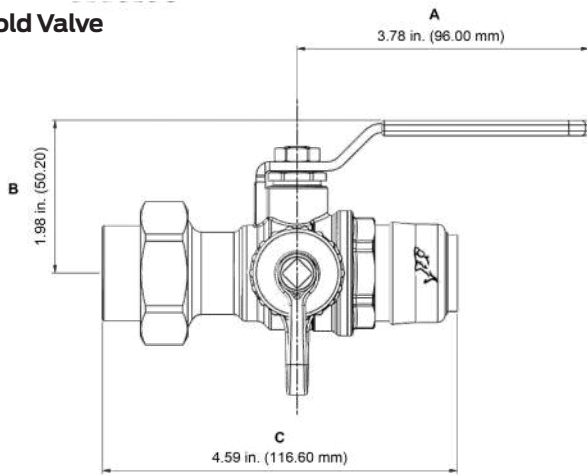

### Hot Valve

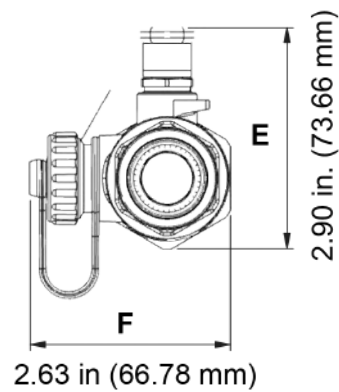
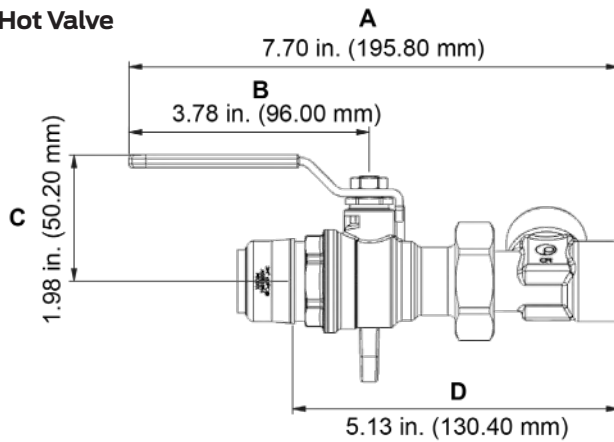

### Relief Valve

