



SharkBite Max™

Elbow with Drain

SharkBite Max™ allows users to connect pipe with ease - no tools needed. This new design features a stainless steel retainer for extra strength, higher pressure ratings (250 psi) and a lower insertion effort than previous versions of SharkBite Brass Push-to-Connect fittings. SharkBite Max fittings do not require a PEX stiffener and are compatible with PEX, copper, CPVC, PE-RT and HDPE*.

Applications

Residential and commercial potable water, recirculation, hydronic heating/cooling (up to 50% glycol concentration) and direct burial (wrapping required).

Specification Data

| Materials | |
|----------------|---------------------|
| Body | Lead-Free DZR Brass |
| O-ring | EPDM |
| Steel Retainer | 304 Stainless Steel |
| Grab Ring | 316 Stainless Steel |

| Pipe Insertion Depth | | Performance | |
|----------------------|-----------------|----------------------|--------------|
| Fitting Size | Insertion Depth | Max Working Pressure | |
| 1/2" | 1.00 in. | Max Pressure | 250 psi |
| 3/4" | 1.25 in. | Max Temperature | 200°F (93°C) |

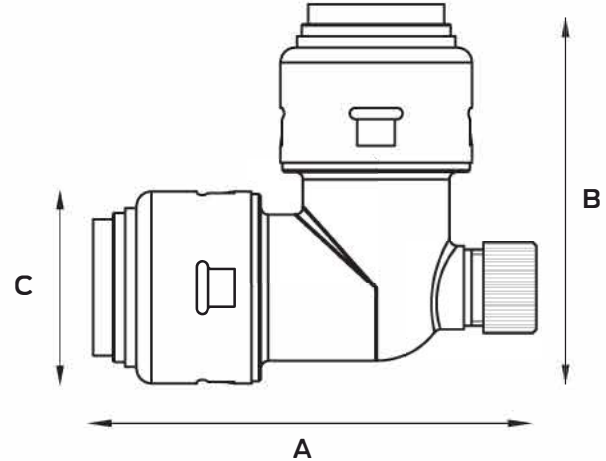

| Dimensions (inches) | | | | |
|---------------------|------|-----|-----|-----|
| Part # | Size | A | B | C |
| UR5248 | 1/2" | 2.3 | 1.9 | 1.0 |
| UR5256 | 3/4" | 2.8 | 2.4 | 1.3 |

Certifications & Listings

ASSE 1061, CSA B125.3, NSF/ANSI 14, NSF/ANSI/CAN 61, NSF/ANSI/CAN 372

For listing information, please contact Customer Service

* HDPE installations must use a tube stiffener. Sold separately by HDPE manufacturer.

| Product Submittal | |
|-------------------|--|
| Name | |
| Date | |
| Architect/Owner | |
| Contractor | |
| Tag | |
| Notes | |

